

Math S-21b – Nonlinear Systems and Linearization
 (Notes by Otto Bretscher, Robert Winters, et al – revised Aug 9, 2005)

Most differential equations and systems of differential equations one encounters in practice are nonlinear. For example, a biologist might model the populations $x(t)$ and $y(t)$ of two interacting species of animals by the following nonlinear system:

$$\begin{cases} \frac{dx}{dt} = x(6 - 2x - y) \\ \frac{dy}{dt} = y(4 - x - y) \end{cases}$$

where the populations are measured in thousands. (To understand the rationale behind these equations, read: J.D. Murray, *Mathematical Biology*, Chapter 3: Continuous Models for Interacting Populations, Springer-Verlag, 1989.)

For given initial values x_0 and y_0 this system has a unique solution (a rigorous proof of this fact is beyond the scope of this course), but it turns out that there is no closed formula for this solution. Still, we can gain a good understanding of the evolution of this system and its long-term behavior by taking a qualitative graphical approach. We can write the system as:

$$\frac{d}{dt} \begin{bmatrix} x \\ y \end{bmatrix} = \begin{bmatrix} x(6 - 2x - y) \\ y(4 - x - y) \end{bmatrix},$$

that is, the solutions are the flow lines of the vector field:

$$\begin{bmatrix} x(6 - 2x - y) \\ y(4 - x - y) \end{bmatrix}.$$

We could use a computer to generate this vector field (or a corresponding direction field), but it turns out that even without the aid of a computer it is not hard to analyze the long-term behavior of the system.

To facilitate this discussion, let us write $f(x, y) = x(6 - 2x - y)$ and $g(x, y) = y(4 - x - y)$. Our task is to draw a rough sketch of the vector field

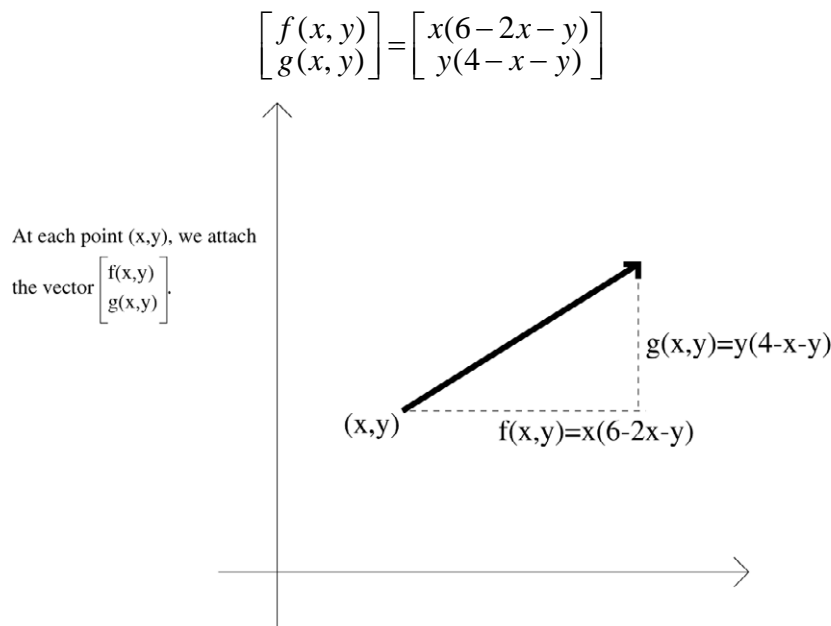

We might start by finding the horizontal and vertical vectors in the field (when $g(x, y) = 0$ or $f(x, y) = 0$, respectively).

Now $g(x, y) = y(4 - x - y) = 0$ when $y = 0$ or $4 - x - y = 0$, that is, when $y = 0$ or $x + y = 4$.

The horizontal line segments indicate that the vectors of the field are horizontal there; at this point, we don't worry about the direction. Next, we find out where the vectors are vertical, that is, where

$$f(x, y) = x(6 - 2x - y) = 0.$$

If we draw the last two figures on the same axes, then we can see the four points where both $f(x, y) = 0$ and $g(x, y) = 0$. These are the **equilibrium solutions** of the system: If the system is initially in one of these states, then it will remain unchanged

(since $\frac{dx}{dt} = 0$ and $\frac{dy}{dt} = 0$).

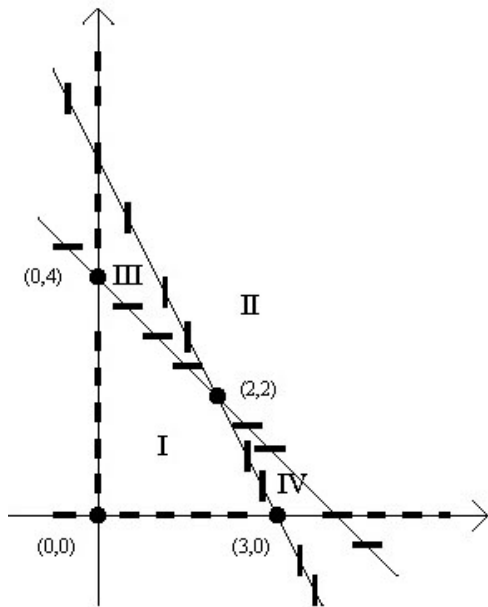
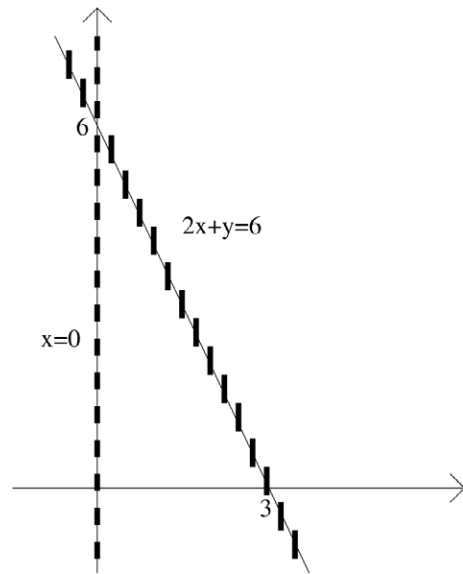
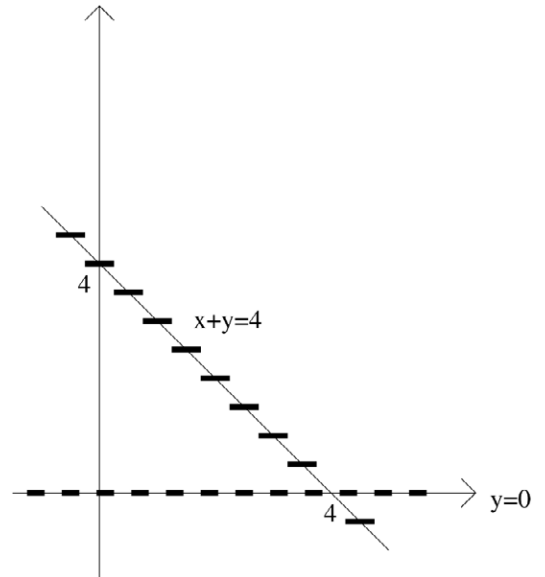

To find the equilibrium solution in the first quadrant, we solve the system

$$\begin{cases} 2x + y = 6 \\ x + y = 4 \end{cases}$$

The equilibria are $(2, 2)$, $(0, 4)$, $(3, 0)$, and $(0, 0)$.

The curves where $f(x, y) = 0$ and $g(x, y) = 0$ are sometimes called the *nullclines* of the system. What happens in the four regions enclosed by the nullclines, labeled (I) to (IV) above? Since neither $f(x, y)$ nor $g(x, y)$ will ever be zero inside one of these regions, the signs of $f(x, y)$ and $g(x, y)$ will remain unchanged throughout a given region (since the functions $f(x, y) = x(6 - 2x - y)$ and $g(x, y) = y(4 - x - y)$ are continuous). All we need to do is determine these signs at one sample point in each region.

We can represent our work in a table:

Region	Sample Point	Sign of $f(x, y)$	Sign of $g(x, y)$	Vector $\begin{bmatrix} f(x, y) \\ g(x, y) \end{bmatrix}$
I	(1, 1)	+	+	up and right
II	(3, 3)	-	-	down and left
III	(0.1, 4)	+	-	down and right
IV	(3, 0.1)	-	+	up and left

Now we can also fill in the direction of the vectors on the nullclines: it has to be compatible with the directions in the adjacent regions.

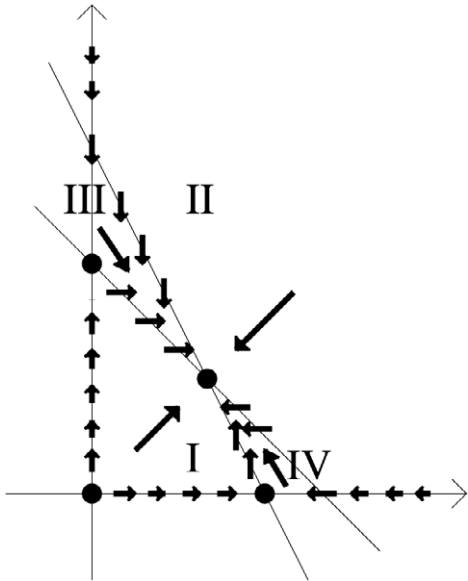

What does this analysis tell us about the long-term behavior of this system? Let us consider various scenarios:

If the point (x_0, y_0) representing the initial populations is located in region III, then the trajectory will move to the right and down, and it cannot “escape” from region III since the vectors along the boundaries point “the other way.” The trajectory will approach the equilibrium point $(2, 2)$.

A similar reasoning shows that a trajectory starting in region IV will approach the equilibrium $(2, 2)$.

A trajectory starting in region I has three “options”: It can approach the equilibrium point $(2, 2)$ while remaining in region I at all times, or it can “cross over” into regions III or IV. The final outcome will always be the same: the trajectory will approach $(2, 2)$.

A trajectory starting in region II has the three options just discussed (for region I), but besides that it may seem conceivable that a trajectory could “merge” with the x -axis or the y -axis, approaching the equilibrium $(3, 0)$ and $(0, 4)$, respectively. Note, however, that there is already a (straight-line) trajectory approaching $(3, 0)$ from the right. But trajectories cannot merge since the trajectory for a given initial value is unique, for positive and negative t (think about it!).

Let us summarize: as long as there are some animals from each species present initially (that is, x_0 and y_0 are both positive), then the system will eventually approach the equilibrium state $(2, 2)$. If $x_0 \neq 0$ and $y_0 = 0$, then the system will approach $(3, 0)$; if $x_0 = 0$ and $y_0 \neq 0$, then it will approach $(0, 4)$.



Below we sketch a phase portrait for this system, for the first quadrant:

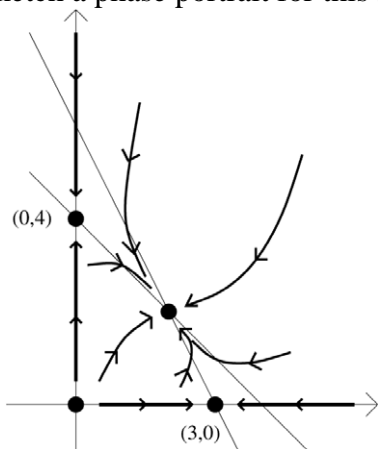

We say that $(2, 2)$ is a **stable equilibrium**, meaning that all trajectories starting near $(2, 2)$ will approach $(2, 2)$ as t goes to infinity (more precisely: there is a disc centered at $(2, 2)$ such that all trajectories with initial value within this disc will approach $(2, 2)$ as t goes to infinity).

Linearization

In applications one is often interested in the behavior of a dynamical system near an equilibrium state. If we zoom in on the phase portrait above near the equilibrium point $(2, 2)$, we see a picture that looks a lot like one of the phase portraits we found when we studied linear systems (see page 415, third figure, the case of two negative eigenvalues).

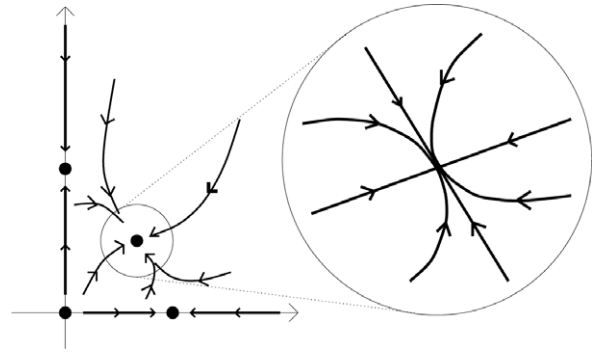

To study the behavior of a nonlinear dynamical system near an equilibrium point, we can *linearize* the system. We will first explain this approach in general and then return to the example discussed above. Consider a system

$$\begin{cases} \frac{dx}{dt} = f(x, y) \\ \frac{dy}{dt} = g(x, y) \end{cases}$$

with an equilibrium solution (a, b) , that is, $f(a, b) = g(a, b) = 0$. In multivariable calculus, you learned that the linear approximation of a function $f(x, y)$ near a point (a, b) is given by

$$f(x, y) \cong f(a, b) + \frac{\partial f}{\partial x}(a, b) \cdot (x - a) + \frac{\partial f}{\partial y}(a, b) \cdot (y - b)$$

To understand this formula, note that the rate of change of f in the x -direction near the point (a, b) is approximately $\frac{\partial f}{\partial x}(a, b)$, so that

$$f(x, b) \cong f(a, b) + \frac{\partial f}{\partial x}(a, b) \cdot (x - a)$$

Likewise, the rate of change of f in the y -direction near (a, b) is approximately $\frac{\partial f}{\partial y}(a, b)$, so that

$$f(x, y) \cong f(x, b) + \frac{\partial f}{\partial y}(a, b) \cdot (y - b) \cong f(a, b) + \frac{\partial f}{\partial x}(a, b) \cdot (x - a) + \frac{\partial f}{\partial y}(a, b) \cdot (y - b)$$

To linearize the system

$$\begin{cases} \frac{dx}{dt} = f(x, y) \\ \frac{dy}{dt} = g(x, y) \end{cases}$$

near an equilibrium point (a, b) means to replace the functions $f(x, y)$ and $g(x, y)$ by their linear approximations. Keeping in mind that $f(a, b) = 0$ and $g(a, b) = 0$, this approximation is

$$\begin{cases} \frac{dx}{dt} = \frac{\partial f}{\partial x}(a, b) \cdot (x - a) + \frac{\partial f}{\partial y}(a, b) \cdot (y - b) \\ \frac{dy}{dt} = \frac{\partial g}{\partial x}(a, b) \cdot (x - a) + \frac{\partial g}{\partial y}(a, b) \cdot (y - b) \end{cases}$$

or

$$\begin{bmatrix} \frac{dx}{dt} \\ \frac{dy}{dt} \end{bmatrix} = \begin{bmatrix} \frac{\partial f}{\partial x}(a,b) & \frac{\partial f}{\partial y}(a,b) \\ \frac{\partial g}{\partial x}(a,b) & \frac{\partial g}{\partial y}(a,b) \end{bmatrix} \begin{bmatrix} x-a \\ y-b \end{bmatrix}$$

We can use the substitution $u = x - a$ and $v = y - b$ to simplify further:

$$\begin{bmatrix} \frac{du}{dt} \\ \frac{dv}{dt} \end{bmatrix} = \underbrace{\begin{bmatrix} \frac{\partial f}{\partial x}(a,b) & \frac{\partial f}{\partial y}(a,b) \\ \frac{\partial g}{\partial x}(a,b) & \frac{\partial g}{\partial y}(a,b) \end{bmatrix}}_{\mathbf{J}} \begin{bmatrix} u \\ v \end{bmatrix}$$

The matrix \mathbf{J} is called the Jacobian matrix of the system at the point (a, b) . Consider the example discussed above, where

$$\begin{aligned} f(x, y) &= 6x - 2x^2 - xy & \frac{\partial f}{\partial x} &= 6 - 4x - y & \frac{\partial f}{\partial y} &= -x \\ g(x, y) &= 4y - xy - y^2 & \frac{\partial g}{\partial x} &= -y & \frac{\partial g}{\partial y} &= 4 - x - 2y \end{aligned}$$

at the point $(2, 2)$, so that

$$\mathbf{J} = \begin{bmatrix} \frac{\partial f}{\partial x}(a,b) & \frac{\partial f}{\partial y}(a,b) \\ \frac{\partial g}{\partial x}(a,b) & \frac{\partial g}{\partial y}(a,b) \end{bmatrix} = \begin{bmatrix} -4 & -2 \\ -2 & -2 \end{bmatrix}.$$

We find the eigenvalues $\lambda_{1,2} = -3 \pm \sqrt{5}$ with associated eigenspaces

$$E_{-3+\sqrt{5}} = \text{span} \begin{bmatrix} 2 \\ -1-\sqrt{5} \end{bmatrix} \quad \text{and} \quad E_{-3-\sqrt{5}} = \text{span} \begin{bmatrix} 2 \\ -1+\sqrt{5} \end{bmatrix}.$$

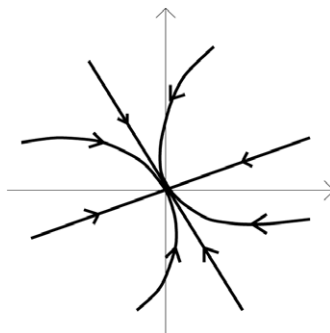

Note that the phase portrait of the linearized system looks a lot like the phase portrait of the original system near the equilibrium point; in this introductory course we cannot make this relationship precise. Let us just state some important facts, without proof. Let \mathbf{J} be the matrix of the linearized system. Then:

- If both eigenvalues of \mathbf{J} have a negative real part, then (a, b) is a stable equilibrium of the original system.
- If \mathbf{J} has at least one eigenvalue with a positive real part, then (a, b) is not a stable equilibrium of the original system.

Example:

Consider the system $\left\{ \begin{array}{l} \frac{dx}{dt} = x(y-1) \\ \frac{dy}{dt} = y(2-x-y) \end{array} \right\}$. Note that $(1, 1)$ is an equilibrium solution of this system.

Is this equilibrium stable?

Answer: The phase plane analysis is inconclusive in this case. We cannot tell whether the trajectories spiral inwards, spiral outwards, or are closed.

Alternatively, we can linearize near $(1, 1)$.

A routine computation shows that $\mathbf{J} = \begin{bmatrix} 0 & 1 \\ -1 & -1 \end{bmatrix}$ with

eigenvalues $\lambda_{1,2} = \frac{-1 \pm i\sqrt{3}}{2}$.

It follows that $(1, 1)$ is a stable equilibrium; the trajectories starting near that point spiral inward, approaching $(1, 1)$.

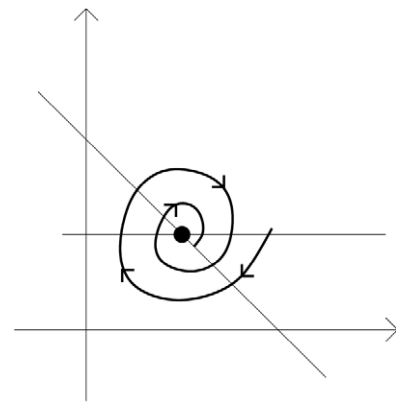
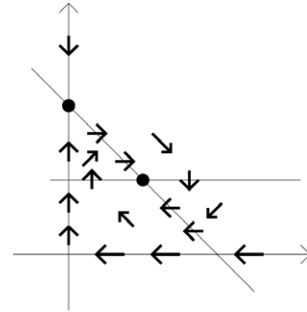

Summary

In this section we discuss two methods that help us analyze a system of the form

$$\left\{ \begin{array}{l} \frac{dx}{dt} = f(x, y) \\ \frac{dy}{dt} = g(x, y) \end{array} \right\}$$

Phase Plane

The trajectories of the system are the flow lines of the vector field

$$\begin{bmatrix} f(x, y) \\ g(x, y) \end{bmatrix}.$$

- To get a sense for this vector field, we first sketch the nullclines $f(x, y) = 0$ (where the vectors are vertical) and $g(x, y) = 0$ (where the vectors are horizontal).
- Next we identify the equilibria, where $f(x, y) = 0$ and $g(x, y) = 0$.
- Then we can use the sample points in the regions between nullclines to determine the direction of the vectors.
- Use the rough vector field drawn in the previous three steps to draw some representative trajectories, and predict the long-term behavior for the various initial values, if possible.

Linearization

Suppose (a, b) is an equilibrium of the system, that is, $f(a, b) = 0$ and $g(a, b) = 0$. Replacing the functions $f(x, y)$ and $g(x, y)$ by their linear approximations near (a, b) , we obtain the linearized system

$$\frac{d}{dt} \begin{bmatrix} u \\ v \end{bmatrix} = \underbrace{\begin{bmatrix} \frac{\partial f}{\partial x}(a, b) & \frac{\partial f}{\partial y}(a, b) \\ \frac{\partial g}{\partial x}(a, b) & \frac{\partial g}{\partial y}(a, b) \end{bmatrix}}_{\mathbf{J}} \begin{bmatrix} u \\ v \end{bmatrix}$$

where $u = x - a$ and $v = y - b$. Then the phase portrait of this linearized system “looks a lot like” the phase portrait of the original system near (a, b) . In particular, if the real parts of both eigenvalues of \mathbf{J} are negative, then (a, b) is a stable equilibrium of the original system. If the real part of at least one eigenvalue of \mathbf{J} is positive, then (a, b) isn't a stable equilibrium of the original system. The matrix \mathbf{J} is called the Jacobian matrix of the system at the point (a, b) .

Exercises

1. The interaction of two species of animals is modeled by

$$\left\{ \begin{array}{l} \frac{dx}{dt} = x(2 - x + y) \\ \frac{dy}{dt} = y(4 - x - y) \end{array} \right\}$$

for $x \geq 0$ and $y \geq 0$.

- Sketch a phase portrait for this system. Make sure that your sketch clearly shows the nullclines and the equilibria.
- There is one equilibrium point (a, b) with $a > 0$ and $b > 0$. Find the Jacobian matrix \mathbf{J} of the system at that point.
- Determine the stability of the equilibrium point (a, b) discussed in part (b).

2. Consider the system

$$\left\{ \begin{array}{l} \frac{dx}{dt} = x(1 - x + ky - k) \\ \frac{dy}{dt} = y(1 - y + kx - k) \end{array} \right\}$$

where k is a constant different from 1 and -1.

- The system above has exactly one equilibrium point (a, b) in the first quadrant with $a > 0$ and $b > 0$. Find this equilibrium point.
- Find the Jacobian matrix at the equilibrium point.
- Determine the stability of the equilibrium point. Your answer may depend on the constant k .

3. The dynamics of a frictionless pendulum of length L are given by the system

$$\begin{cases} \frac{d\alpha}{dt} = \omega \\ \frac{d\omega}{dt} = -\frac{g}{L} \sin \alpha \end{cases}$$

where α is the angle the rod of the pendulum makes with the vertical line, $\omega = \frac{d\alpha}{dt}$ is the angular velocity, and g is the gravitational constant.

- Sketch a phase portrait for this system. Think about the trajectories in terms of the motion of a frictionless pendulum.
- Find the Jacobian matrix at all equilibrium point, and compute the eigenvalues. What does the answer tell you about the stability of the equilibria?

4. Consider the system

$$\begin{cases} \frac{dx}{dt} = x^2 + y^2 - 1 \\ \frac{dy}{dt} = xy \end{cases}.$$

Sketch a phase plane for this system. Make sure that your sketch clearly shows the nullclines and the equilibria. Which equilibria are stable?

5. In an article on insect dispersion we found the differential equation

$$\frac{d^2u}{dt^2} = f(u) - \frac{du}{dt}$$

where $f(u)$ is the function graphed below:

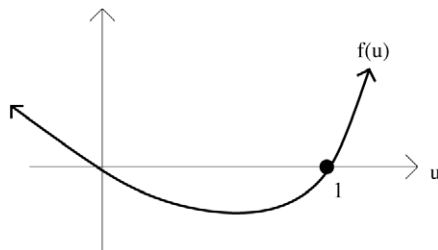

We can introduce the auxiliary function $v = \frac{du}{dt}$ and write the second order differential equation above as a system:

$$\begin{cases} \frac{du}{dt} = v \\ \frac{dv}{dt} = f(u) - v \end{cases}$$

Sketch the phase portrait of this system, clearly identifying the nullclines and the equilibria. Use Jacobian matrices to determine the stability of the equilibria.